

INSTRUCTION MANUAL

BP-480

Wood Band Saw

465mm Throat x 310mm Height Capacity



W4344

The logo for Hare & Forbes Machinery House features the company name in a stylized font. 'HARE' and 'MACHINERY' are in blue, '&' is in white with a blue outline, 'FORBES' and 'HOUSE' are in red. The text is framed by a blue border that curves around the top and bottom. In the background, there is a close-up image of a mechanical part, possibly a saw blade or a motor component, with a circular dial and various markings.

HARE & FORBES

MACHINERY HOUSE

Established 1930

Distributors of New & Used Workshop Equipment

WOOD BANDSAW

MODEL: BP-480 (W4344)

OPERATION MANUAL AND PARTS LIST

TABLE OF CONTENT

1. SPECIFICATIONS	1
2. WARNINGS	2
3. SAFETY INSTRUCTION FOR MACHINERY	3
4. IDENTIFICATION	4
FRONT SIDE OF BAND SAW	4
REAR OF BAND SAW	5
5. OPERATING INSTRUCTION	6
LIFTING AND PLACING	6
ASSEMBLING	6
ADJUSTING 90 DEGREE TABLE STOP	6
ASSEMBLING RIP FENCE	7
CHANGING BLADES	7
ADJUSTING THE TENSION OF BLADE	7
ADJUSTING UPPER BLADE GUIDE ASSEMBLY	8
DUST COLLECTION	8
SETTING THE CUTTING HEIGHT	8
MITER GAUGE ADJUSTMENT	9
SAFETY DEVICE	9
6. STEPS FOR THE TABLE PARALEEL ADJUSTMENT	10
7. PARTS LIST	11

FEATURES:

The 19”(480mm) bandsaw is a well designed industrial machine that provide variety of wood work functions to meet your higher need of a bandsaw. Followings are the basic functions you will find in this machine:

1. *Quick Changed Saw Blade System* gives you an easy way to replace saw blade to cut different quality wood materials.
2. *Adjustable Rip Fence* can assist you to cut desired shapes.
3. *Accurate Miter Gauge* can let you create any curves you desire.
4. *Effective Ball Bearing Guide System* will let the band saw blade run smoother.
5. *Humanized Dust Chutes* collect extra wood-chips and give you a better working environment.
6. *Extended 12” Height Space* provides you a bigger working space to cut wider and higher wood selections.

1. SPECIFICATIONS

Horse Power	2HP
Cutting Height	12"(300mm)
Max. Cutting Width	18-1/4"(462mm)
Max. Cutting (with Rip Fence)	16-5/8"(422mm)
Saw Blade (L)	143"/3632mm
Saw Blade (W)	1/8" to 1" (Standard 3/4")
Saw Blade Speed	1,500/3,200SFPM
Table Size	19" x 19"(480x480mm)
Table Tilting	Left-10° / Right-45°
Wheel Size	19"(480mm)
Table Height From Ground	37.5"(950mm)
Dust Chute Diameter	φ 4" x 2
N.W./G.W.	145 / 174 KGS
Appearance	36" x 30" x 78"
Packing Size (L x W x H)	34" x 20" x 85"

2. WARNINGS



WARNING

- Misuse of this machine can cause serious injury.
- For safety, machine must be set up, used and serviced properly.
- Read, understand and follow instructions in the operator and parts manual which was shipped with your machine.

When setting up machine:

- Always avoid using machine in damp or poorly lighted work areas.
- Always be sure machine is securely anchored to the floor.
- Always keep machine guards in place.
- Always put start switch in "OFF" position before plugging in machine.

When using machine:

- Never operate with machine guards missing.
- Always wear safety glasses with side shields.
- Never wear loose clothing or jewelry.
- Never overreach - you may slip and fall into the machine.

- Never leave machine running while you are away from it.
- Always shut off the machine when not in use.

When servicing machine:

- Always unplug machine from electrical power while servicing.
- Always follow instructions in operators and parts manual when changing accessory tools or parts.

You - the stationary power tool user - hold the key to safety.

Read and follow these simple rules for best results and full benefits from your machine. Use properly, this machine is among the best in design and safety. However, any machine used improperly can be rendered inefficient and unsafe. It is absolutely mandatory that those who use our products be properly trained in how to use them correctly. Should read and understand the Operators and Parts Manual as well as all labels affixed to the machine. Failure in following of these warnings can cause serious injuries

MAHINERY GENERAL SAFETY WARNINGS

1. Always wear protective eye wear when operating machinery. Eye wear shall be impact resistant, protective safety glasses with side shields. Not using eye wear which could result in severe injury from breakage of eye protection.
2. Wear proper apparel. No loose clothing or jewelry which can get caught in moving parts. Rubber soled footwear is recommended for best footing.
3. Do not overreach. Failure to maintain proper working position can cause you to fall into the machine or cause your clothing to get caught - pulling you into the machine.
4. Keep guards in place and in proper working order. Do not operate the machine with guards removed.
5. Avoid dangerous working environments. Do not use stationary machine tools in wet or damp locations. Keep work areas clean and well lit. Special electricians should be used when working on flammable materials.
6. Avoid accidental starts by being sure the start switch is "OFF" before plugging in the machine.
7. Never leave the machine running while unattended. Machine shall be shut off whenever it is not in operation.
8. Disconnect electrical power before servicing. Whenever changing accessories or general maintenance is done on the machine, electrical power to the machine must be disconnected before work is done.
9. Maintain all machine tools with care. Follow all maintenance instructions for lubricating and the changing of accessories. No attempt shall be made to modify or have makeshift repairs done to the machine. This not only voids the warranty but also renders the machine unsafe.
10. Machinery must be anchored to the floor.
11. Secure work. Use clamps or a vise to hold work, when practical. It is safer than using your hands and it frees both hands to operate the machine.
12. Never brush away chips while the machine is in operation.
13. Keep work area clean. Cluttered area invite accidents.
14. Remove adjusting keys and wrenches before turning machine on.
15. Use the right tool. Don't force a tool or attachment to do a job it was not designed for.
16. Use only recommended accessories and follow manufacturer's instructions pertaining to them.
17. Keep hands in sight and clear of all moving parts and cutting surfaces.
18. All visitors should be kept at a safe distance from the work area. Make workshop completely safe by using padlocks, master switches, or by removing starter keys.
19. Know the tool you are using - its application limitations, and potential hazard.

GENERAL ELECTRICAL CAUTIONS

This saw should be grounded in accordance with the National Electrical Code and local codes and ordinances. This work should be done by a qualified electrician. The saw should be grounded to protect the user from electrical shock.

Caution: For circuits which are far away from the electrical service box, the wire size must be increased in order to deliver ample voltage to the motor. To minimize power losses and to prevent motor overheating and burnout, the use of wire sizes for branch circuits or electrical extension cords according to the following table is recommended.

3. SAFETY INSTRUCTION FOR MACHINERY

<ol style="list-style-type: none"> 1. Always wear leather gloves when handling saw blade. The operator shall not wear gloves when operating the machine. 2. All doors shall be closed, all panels replaced, and other safety guards in place prior to the machine being started or operated. 3. Be sure that the blades are not contact with the workpiece when the motor is started. The motor shall be started and you should allow the saw to come up to full speed before bringing the saw blade into contact with the workpiece. 4. Keep hands away from the blade area. See Figure A. 5. Remove any cut off piece carefully while keeping your hands free of the blade area. 6. Saw must be stopped and electrical supply must be cut off before any blade replacement or adjustment of blade support mechanism is done, or before any attempt is made to change the drive belts or before any periodic service or maintenance is performed on the saw. 7. Remove loose performed on the unnecessary workpieces from area before staring machine. 8. Bring adjustable saw guides and guards as close as possible to the workpiece. 	<ol style="list-style-type: none"> 9. Always wear protective eye wear when operating, servicing, or adjusting machinery. Eyewear shall be impact resistant, protective safety glasses with side shields. Not using eye wear which could result in severe injury from breakage of eye protection. See Figure B. 10. Nonslip footwear and safety shoes are recommended. See Figure C. 11. Wear ear protectors (plugs or muffs) during extended periods of operation. See Figure D. 12. Wear mask to operate machine. See Figure E. 13. Do not smoke during operating machine. See Figure F. 14. The workpiece, or part being sawed, must be securely clamped before the saw blade enters the workpiece. 15. Remove cut off pieces carefully, keeping hands away from saw blade. 16. Saw must be stopped and electrical supply cut off or machine unplugged before reaching into cutting area. 17. Avoid contact with coolant, especially guarding your eyes.
---	--



A



B

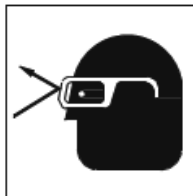

C

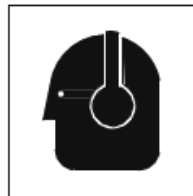

D



E

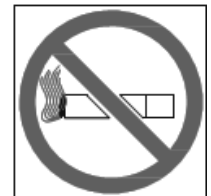

F

4. IDENTIFICATION

Throughout this document, we make reference to various systems and components on the saw. The two illustrations on these pages will provide you with an overall frame of reference for the location and position of the various components.

Where detailed illustrations for various subsystems will be helpful, you will find these illustrations accompanying the specific test for each subsystem and its components.

FRONT SIDE OF BAND SAW

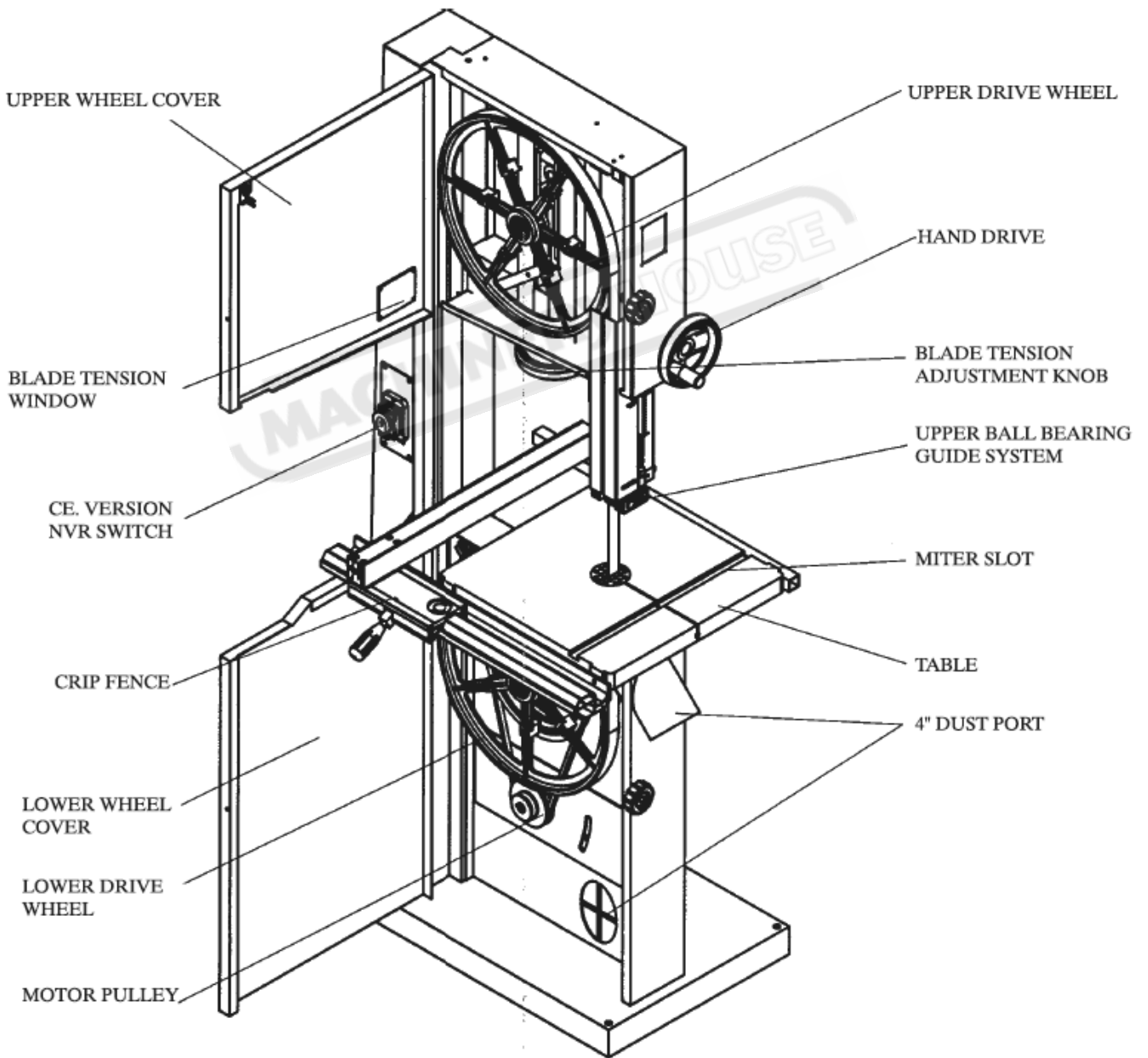

REAR OF BAND SAW

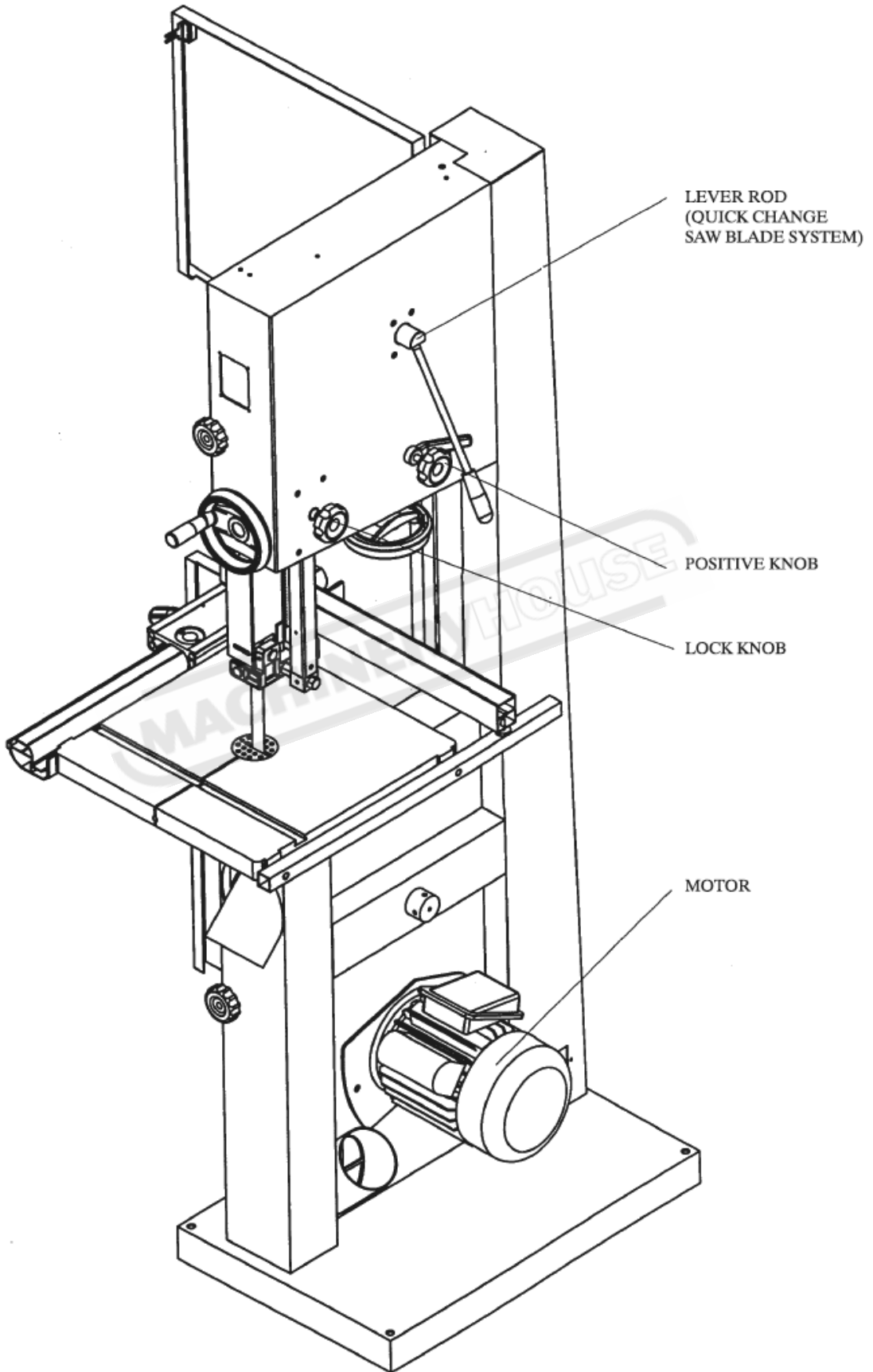

5. OPERATING INSTRUCTION

LIFTING AND PLACING

On the day that the machine arrives, make sure that a crane or forklift with sufficient capacity is available to unload the machine from the vehicle.

Ensure access to the chosen site is clear and that doors and ceilings are sufficiently high and wide enough to receive the machine.

1. Move the crate to the chosen location, then remove the crate from the base
2. Unbolt the bandsaw from the pallet
3. Use the eye bolt supplied with the machine to attach a certified lifting sling or hook (Refer Fig. 1).
4. Slowly lift the machine off the pallet and carefully place it into position.
5. Once machine is set in place it is recommended to level the machine and bolt it in place.

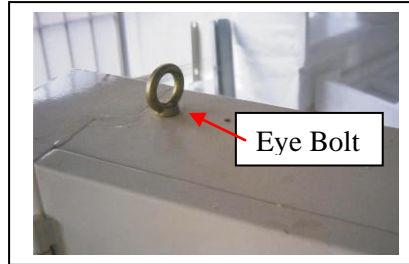

Figure 1

ASSEMBLING

1. Attach the hand wheel (see Figure 2) to the machine.

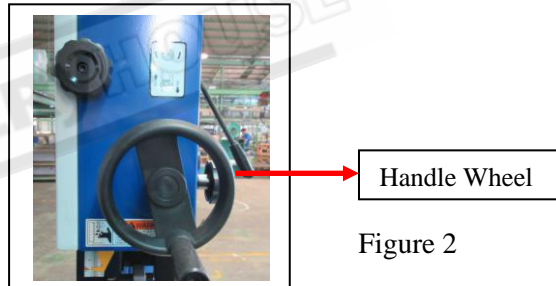

Figure 2

2. Slide the table slot to the saw blade and slowly move to the center of the table. Adjust the table until the saw blade is in the center of table insert.
3. Install table insert. Then, install table gap screw assembly, secure with (1) M8 nut, (2) M8 flat washer and tighten gap screw. (see Figure 3)

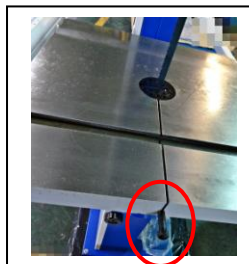

Figure 3

4. Make sure the table is in the center. Then, secure table to trunnion. Please use (1) M8 flat washer (2) M8 spring washer, and (3) M8x25 hex head bolt to secure. (see Figure 4)



Figure 4

ADJUSTING 90 DEGREE TABLE STOP

1. Unplug power cord. Loosen the lock knobs (see Figure 5) and tilting table left until it rests against table stop bolt M8. (A, Fig. 6)



Figure 5

2. Use a protector placed on the table and against the blade (Fig. 7) to see if the table is 90 degree to the table. If it is not 90 degree, you can use micro-adjust knob. Please lock the lock knob.



Figure 6



Figure 7

ASSEMBLING RIP FENCE

1. Setting the fixed base to the cast iron table with two M6x20 hex head bolts and two M6 spring washers. (Fig. 8)
2. Setting the square tube to the table with two M6x16 hex socket bolts.
3. Setting the fence to the fence body. Place the fence assembly on the fixed base and slide the fence on its guides until it is the required distance from the blade.
4. Check the scale, make sure the distance between the edge of the miter slot and both the front and rear of the rip fence. Adjust so both distances are equal.
5. Lock the fence by pushing the locking handle.

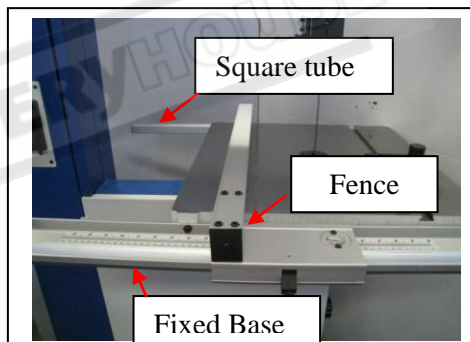

Figure 8

CHANGING BLADES

1. Unplug power cord.
2. Remove the table insert and table pin.
3. Open upper and lower wheel cover.
4. Loosen the upper and lower blade guide system and bearing.
5. Loosen quick change saw blade system lever on rear of bandsaw.(see Figure 9)
6. Remove the blade and guide new blade through table slot. Place blade in upper and lower ball bearing guides system.
7. Replace blade in the MIDDLE of the upper and lower wheel. If the blade is not in the right position, you must relax the fixed handle and adjust the tracking control knob.(see Figure 9)
8. Replace the table insert and table pin.
9. Adjust the blade tension and blade tracking if the blade width is different.

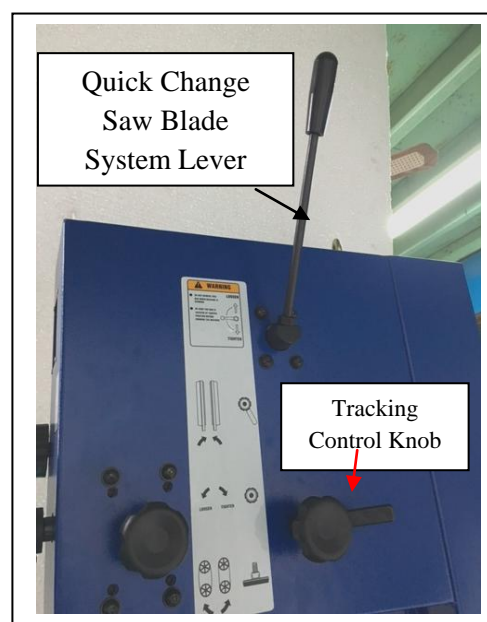

Figure 9

ADJUSTING THE TENSION OF BLADE

Blade tension is set by a spring loaded tension mechanism on the upper wheel. Check the level of the tension device before cutting. The tension for various blade widths as indicated on the window of upper wheel cover.

Turn the blade tension hand wheel (see Figure 10) and see the saw tension instruction (see Figure 11) indicated on the window of upper wheel cover.



Figure 10

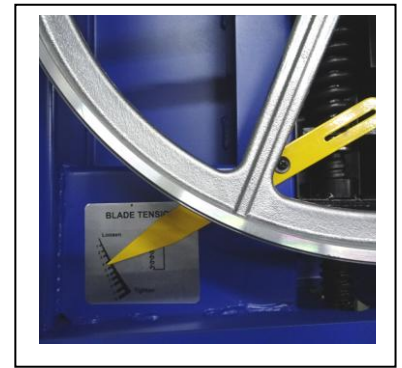

Figure 11

ADJUSTING UPPER BLADE GUIDE ASSEMBLY

1. Set the bearing of upper and lower blade guide within approx. 0.5mm of the blade. Make sure the bearing and the back of the blade approx. 0.5mm. (see Figure 12 and Figure 13)
2. Do not set the bearing too close. The friction generates heat, which may have an adverse effect on the bearings and the saw blade.



Figure 12



Figure 13

DUST COLLECTION

The band saw is recommended to be connected to dust collect. There are two 4" dust ports (see Figure 14) to attach with 4" steel clamping.



Figure 14

SETTING THE CUTTING HEIGHT

The upper blade guide should always be set as close practical against the work. To adjust, loosen the hand wheel (see Figure 15) at the side of housing and see the blade guide to the required height. Then, tighten after setting.



Figure 15

MITER GAUGE ADJUSTMENT

1. Place the miter gauge in the table slot.
2. Loosen the clamp screw on the miter gauge.
3. Adjust the desired angle of cutting on the miter gauge.
4. Tighten the clamp screw. (see Figure 16)



Figure 16

SAFETY DEVICE

1. Limit switch (see Figure 17) inside the machine body for cutting off the power while door opening during operation.
2. Added door lock (see Figure 18) to link upper and lower doors in between. To prevent the door being suddenly opened during operation.



Figure 17

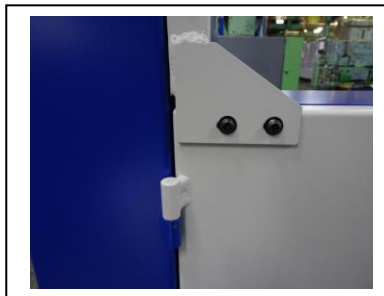

Figure 18

REMINDER

Once completing assembly, please test run the machine to ensure it is properly connected to power and safety components are functioning correctly.

If you find an unusual problem during the test run, please stop the machine immediately. Disconnect the machine from power and fix the problem before operating the machine again.

6. STEPS FOR THE TABLE PARALEEL ADJUSTMENT

1. Insert table pin into table groove. (see Figure 1)

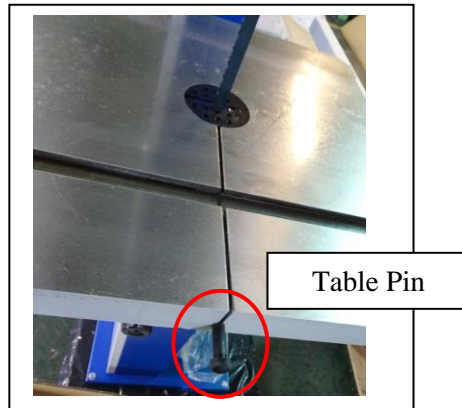

Figure 1

2. Use a ruler gauge and put it on the table. Adjust the position of the table pin (adjust the depth of the pin) and adjust the parallel of the table by using the feller gauge. The tolerance for the table parallel is within 0.4mm.
3. When adjusting the table, the table edge can be higher than the middle position about 0.4mm. Edge cannot lower than the middle part of the table. (see Figure 2 & 3)



Figure 2

NOTE: To insert the table pin deeper, the middle part of the table will be lower.

4. Follow above steps to finish the table parallel adjustment.



Figure 3

TROUBLE SHOOTING:

In case if the table pin stuck because you push it to deep, use a round bar $\phi 5\text{mm} \sim \phi 8\text{mm}$ and soft hammer to knock the table pin out from inside of the table. Please be aware of your fingers!

7 PART LIST

Instruction Manual for DP 480 (W4344)
MODEL NO. : W4344

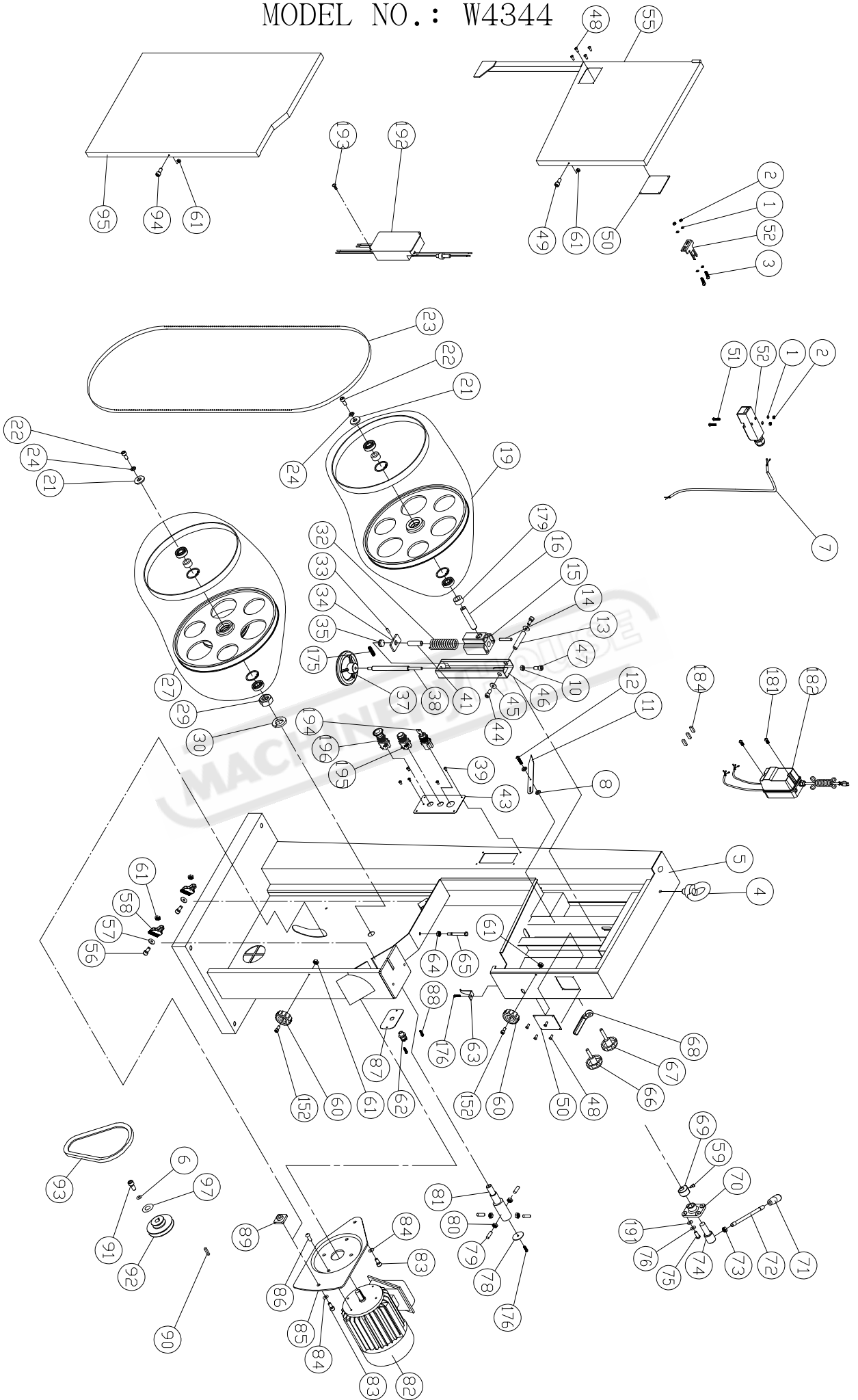

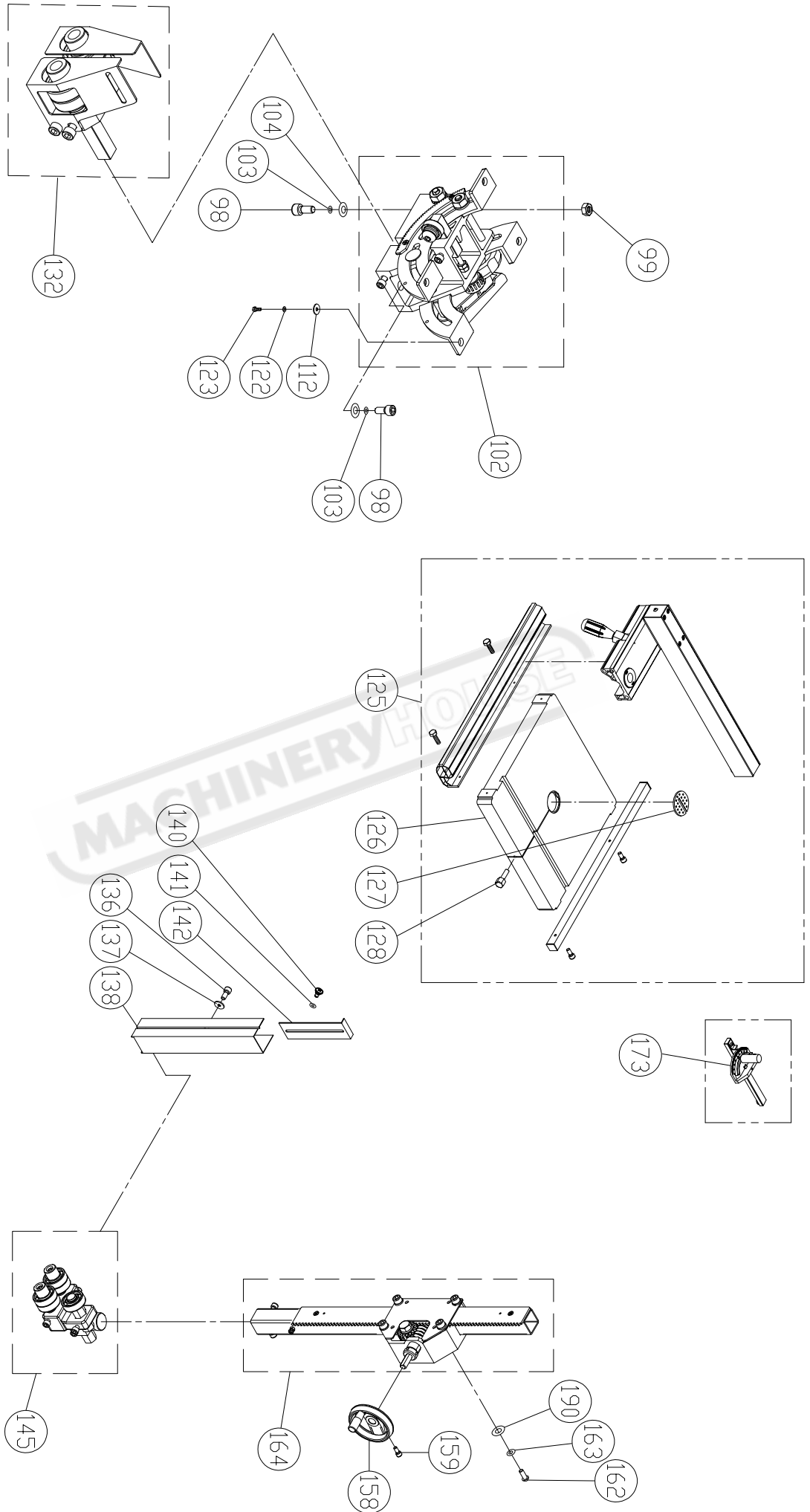

ITEM	PART NO.	DESCRIPTION	SIZE	Q`TY
1	WF040808	FLAT WASHER	M4x ψ 8	6
2	NH040700	NUT	M4	4
3	SP040200	PAN HEAD SCREW	M4x8	2
4	995101	RING	M10	1
5	136121V	MACHINE BODY		1
6	WS080000	SPRING WASHER	M8	1
7	IC135040	SWITCH CORD		1
8	WF061310	FLAT WASHER	M6x ψ 13	2
10	NH061000	NUT	M6	1
11	135040	POINTER		1
12	135073	STEP SCREW		1
13	135012	UPPER SHAFT		1
14	PS053600	SPRING PIN	ψ 5x36	1
15	135017	UPPER WHEEL SHAFT HINGE		1
16	135066	UPPER WHEEL SHAFT		1
19	AB136024T-PU	UPPER WHEEL	ψ 19"	1
21	WF083030	FLAT WASHER	M8x ψ 30	2
22	SR089400	HEX SOCKET BOLT	M8x16	2
23	136010	SAW BLADE	6PTI / 143"/3632.24.2x3/4"x0.5mm	1
24	WS080000	SPRING WASHER	M8	2
27	AB136022T-PU	LOWER WHEEL	ψ 19"	1
29	NH633801	NUT	1"-14 UNF	1
30	WS630000	SPRING WASHER	1"	1
32	135032	SPRING		1
33	PS031600	PIN	ψ 3x16	1
34	135042	LOCATE BLOCK		1
35	994301	BEARING	51201	1
37	135002	HANDLE WHEEL		1
38	136007	ADJUSTING BOLT		1
39	SF050200	PAN HEAD BOLT W/FLANGE	M5x10	4

ITEM	PART NO.	DESCRIPTION	SIZE	Q`TY
41	135067	BUSHING		1
43	136369U	SWITCH PLATE		1
44	SR089400	HEX SOCKET BOLT	M8x16	2
45	WF083030	FLAT WASHER	M8x ψ 30	2
46	135016	UPPER WHEEL SLIDING BRACKET		1
47	SR061000	HEX SOCKET BOLT	M6x50	1
48	BR000041	RIVET	ψ 3.2x6	8
49	SR060200	HEX SOCKET BOLT	M6x10	1
50	135004	LIMPID PIECE		2
51	SF040700	PAN HEAD BOLT W/FLANGE	M4x35	2
52	136457	DOOR LATCH SWITCH(ASM)	AZD-S11	1
55	136122U	UPPER WHEEL COVER		1
56	SH060500	HEX HEAD BOLT	M6x25	2
57	WF061310	FLAT WASHER	M6x ψ 13	2
58	135051	BRUSH		2
59	SR060500	HEX SOCKET BOLT	M6x25	1
60	135041	KNOB		2
61	NL061000	NYLON NUT	M6	6
62	136013	STRAIN RELIEF		1
63	135011	HEIGHT POINTER		1
64	NH081300	NUT	M8	1
65	SH081800	HEX HEAD BOLT	M8x90	1
66	135022	KNOB SCREW		1
67	135020	KNOB SCREW		1
68	135028	LOCATE HANDLE	M10	1
69	135030	CAM		1
70	135038	LOCATE BLOCK		1
71	620021	KNOB		1
72	620020	LEVER ROD		1
73	NH121900	NUT	M12	1

ITEM	PART NO.	DESCRIPTION	SIZE	Q`TY
74	135036	SHAFT		1
75	SJ080400	HEX SOCKET BOTTOM HEAD SCREW	M8x20	4
76	WS080000	SPRING WASHER	M8	4
78	135013	COVER		1
79	SS080400	SET SCREW	M8x20	4
80	NH081300	NUT	M8	4
81	135005	LOWER WHEEL SHAFT		1
82	ABMH135020N	MOTOR	1.5KW(8A)1PH 50HZ 240V	1
83	SR100500	HEX HEAD BOLT	M10x25	2
84	WS100000	SPRING WASHER	M10	2
85	135064	MOTOR BRACKET		1
86	SJ080400	HEX SOCKET BOTTOM HEAD SCREW	M8x20	4
87	136475	PLATE		1
88	SF050200	PAN HEAD BOLT W/FLANGE	M5x10	2
89	135065	LOCATE BLOCK		1
90	KS050535	KEY	5x5x35	1
91	SH080402	HEX HEAD BOLT	M8x20(L.H)	1
92	135008	MOTOR PULLEY		1
93	LA420000	V-BELT	A42	1
94	SR060200	HEX SOCKET BOLT	M6x10	1
95	136123U	LOWER WHEEL COVER		1
97	WF083030	FLAT WASHER	M8x30	1
98	SR100700	HEX SOCKET BOLT	M10x35	2
99	NH101700	NUT	M10	1
102	AB135021	TRUNNION SUPPORT BRACKET(ASM)		1
103	WS100000	SPRING WASHER	M10	2
104	WF102325	FLAT WASHER	M10x ψ 23	2
112	WF081820	FLAT WASHER	M8x ψ 18	4
122	WS080000	SPRING WASHER	M8	4
123	SH089400	HEX HEAD BOLT	M8x16	4

ITEM	PART NO.	DESCRIPTION	SIZE	Q`TY
125	AB198006	18" FENCE SET		1
126	136004	TABLE	19"x19"	1
127	135010	TABLE INSERT		1
128	100038	TABLE PIN		1
132	AB135095B	LOWER BLADE GUIDE SUPPORT		1
136	SR050200	HEX SOCKET BOLT	M5x10	2
137	WF051210	FLAT WASHER	M5x ψ 12	2
138	135034	PROTECT COVER(ASM)		1
140	135073	STEP SCREW		1
141	135054	FIBER WASHER	ψ 13x6x1.2	1
142	135037	SLIDING PLATE		1
145	AB135092	UPPER BLADE GUIDE SUPPORT		1
152	SR060400	HEX SOCKET BOLT	M6x20	2
158	135006	HANDLE WHEEL		1
159	SR060400	HEX SOCKET BOLT	M6x20	1
162	SJ080400	HEX SOCKET BOTOM HEAD SCREW	M8x20	4
163	WS080000	SPRING WASHER	M8	4
164	AB135050	GUIDE BRACKET(ASM)		1
173	AB198101	MITER GAUGE ASS'Y		1
175	SS069300	SET BOLT	M6x10	1
176	SF050200	PAN HEAD BOLT W/FLANGE	M5x10	2
179	612112	BUSHING		1
181	SF050200	PAN HEAD BOLT W/FLANGE	M5x10	2
182	ABID12081F2-E	MAGNETIC SWITCH	2HP/1PH/50HZ/240V+2A	1
184	136019	WIRE CONECTOR	224-201	3
185	SF059300	PAN HEAD BOLT W/FLANGE	M5x12	1
186	SH069340	HEX HEAD BOLT	M6x12	1
190	WF081818	FLAT WASHER	M8x ψ 18	4
191	WF081820	FLAT WASHER	M8x ψ 18	4
192	136374	FIRM ELECTRONIC IC	DC90V	1

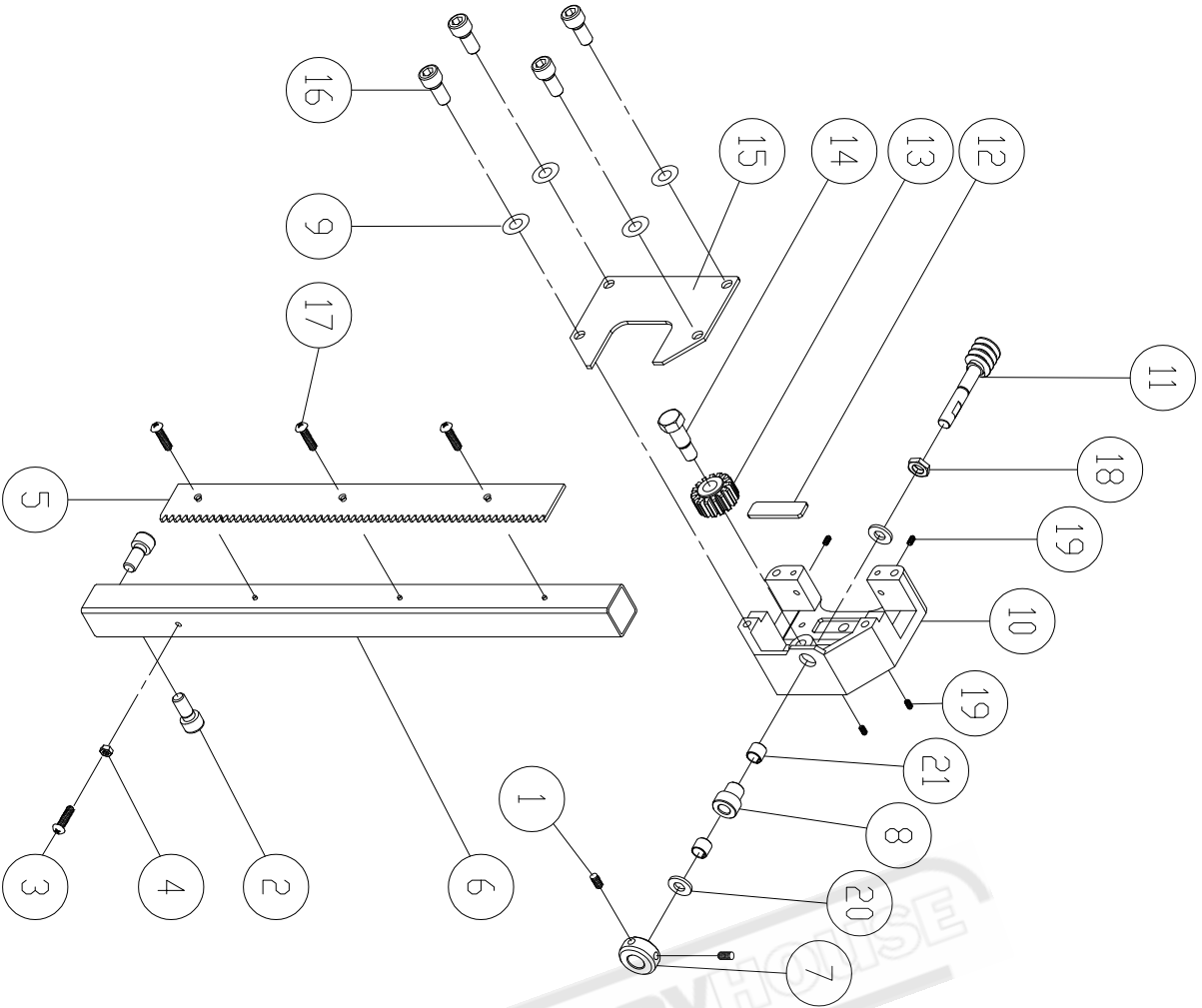

Item	Part ID	Description	Size	Qty
21	BD101201	BUSHING BEARING	DU 10x12	2
20	200069	FIBER WASHER		2
19	990306	SET BOLT	M7x10	4
18	136473	NUT	M16xP1.5	1
17	SN049200	COUNTER SUNK BOLT	M4x8	3
16	SR089400	HEX SOCKET BOLT	M8x16	4
15	135046	COVER		1
14	016320	FIXED BOLT		1
13	135049	GEAR		1
12	135062	FIXED PLATE		1
11	135033	WDRM CYLINDER		1
10	135050	GUIDE BRACKET		1
09	WS080000	SPRING WASHER	M8	4
08	136453	BUSHING		1
07	135015	LOCATE BUSHING		1
06	135047	UPPER GUIDE HOSE		1
05	135029	RACK		1
04	NH040700	NUT	M4	1
03	SP040200	PAN HEAD BOLT	M4x10	1
02	SR069400	HEX SOCKET BOLT	M6x16	2
01	SS050100	SET BOLT	M5x5	2

MODEL NO. : W4344
 PART NO. : AB135050 GUIDE BRACKET (ASM)

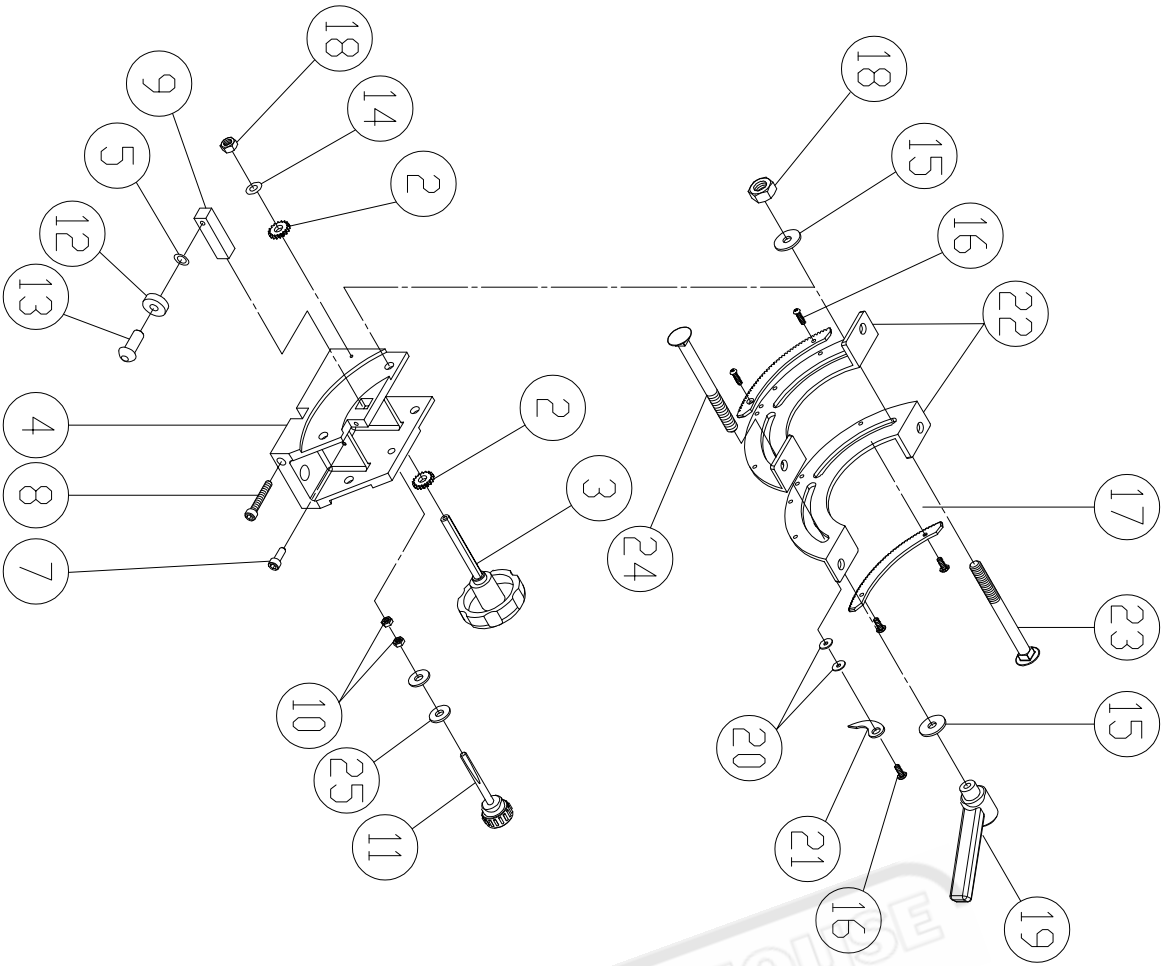

MODEL NO.:W4344
PART NO.: AB135021 TRUNNION SUPPORT BRACKET (AMS)

Item	Part No	Description	Size	Qty
25	WF061310	FLAT WASHER	M6xØ13	2
24	SC081700	CARRIAGE BOLT	M8x85	1
23	SC081600	CARRIAGE BOLT	M8x80	1
22	135025	TRUNNION PLATE		2
21	135078Y	POINTER		1
20	WF040808	FLAT WASHER	M4xØ8	2
19	135044	HANDLE	M8x25	1
18	NL081300	NYLON NUT	M8	2
17	135052	GEAR PLATE		2
16	SP049100	PAN HEAD BOLT	M4x6	5
15	WF081820	FLAT WASHER	M8xØ18	2
14	WS080000	SPRING WASHER	M8	1
13	SJ100400	HEX SOCKET BOTTOM HEAD SCREW	M10x20	1
12	BB60002A	BALL BEARING	6000ZZ	1
11	135009	ADJUST BAR		1
10	NH061000	NUT	M6	2
09	135045	ADJUST BLDCK		1
08	SR061000	HEX SOCKET BOLT	M6x50	1
07	SR060400	HEX SOCKET BOLT	M6x20	1
05	WF102010	FLAT WASHER	M10xØ20	1
04	135021	TRUNNION SUPPORT BRACKET		1
03	135063	KNDB		1
02	135061	SMALL GEAR		2

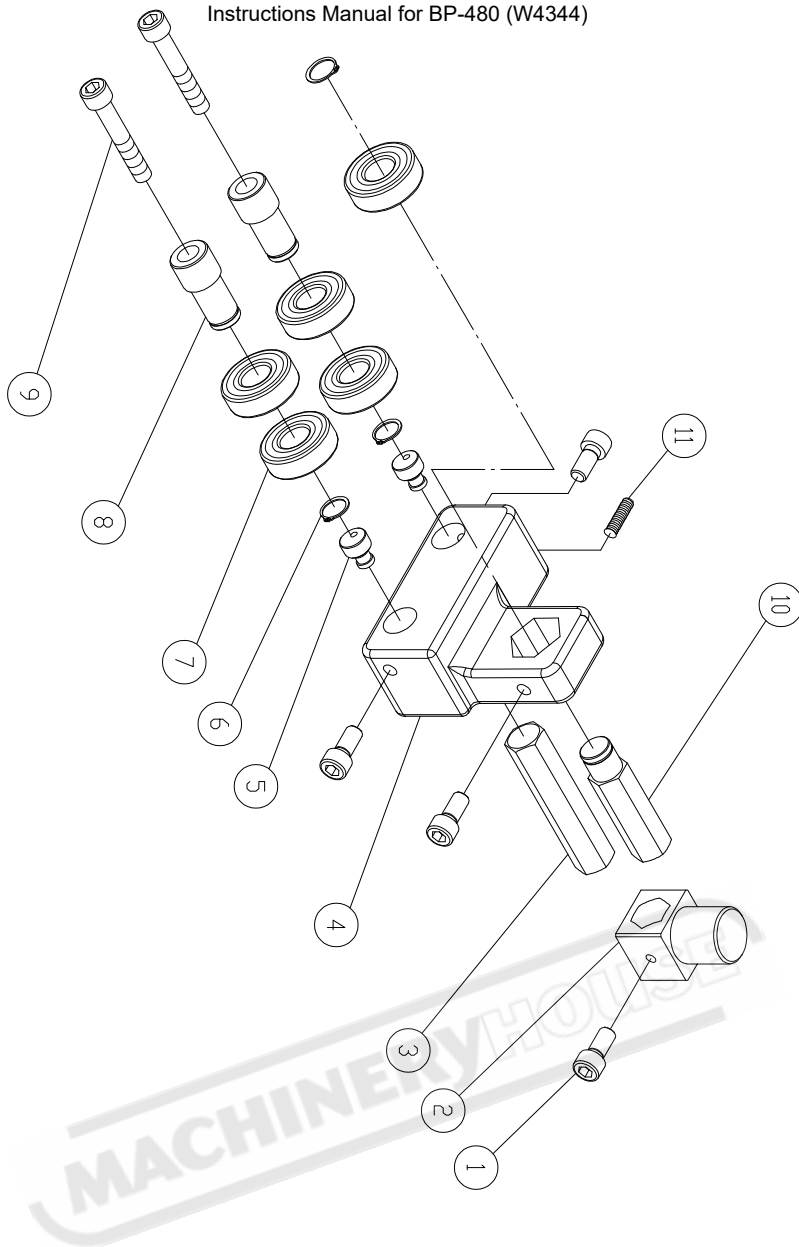

MODEL NO.:W4344
PART NO.:AB135092
UPPER BLADE GUIDE SUPPORT (ASM)

Item	Part ID	Description	Size	Qty
1	SR069400	HEX SOCKET BOLT	M6x16	4
2	135057	UPPER GUIDE SUPPORT BLOCK		1
3	135053	ADJUST BAR		1
4	135091	UPPER BLADE GUIDE SUPPORT		1
5	135124	BIAS SHAFT		2
6	RS150000	RING	S15	3
7	BB620202A	BALL BEARING	6202ZZ	5
8	136445	HANDLE BUSHING		2
9	SR060703	HEX SOCKET BOLT	M6x35	2
10	135060	UPPER SPACING SLEEVE		1
11	SS060200	SET BOLT	M6x10	1

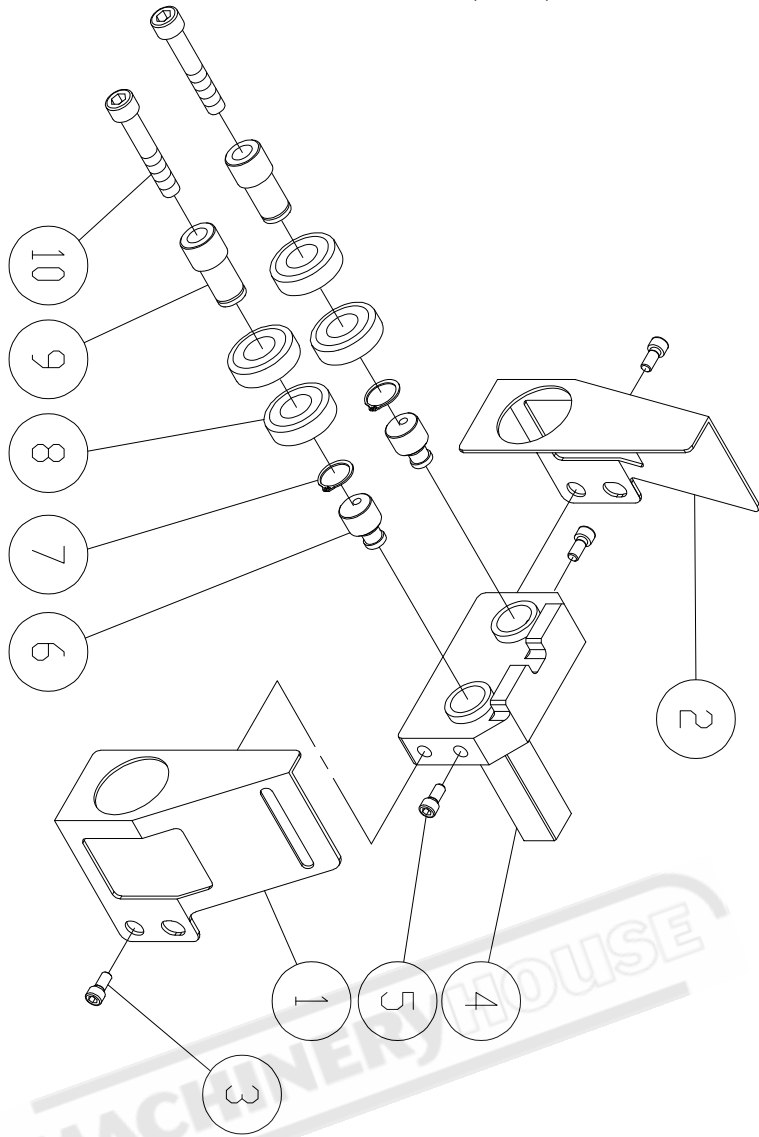

MODEL NO.:W4344
PART NO.: AB135095B
UPPER BLADE GUIDE SUPPORT (ASM)

Item	Part No	Description	Size	Qty
1	135272	RIGHT COVER		1
2	135273	LEFT COVER		1
3	SR060200	HEX SOCKET BOLT	M6x10	2
4	135274	LOWER BLADE GUIDE SUPPORT		1
5	SR069400	HEX SOCKET BOLT	M6x16	2
6	135124	BIAS SHAFT		2
7	RS150000	RETAINING RING	S15	2
8	BB620202A	BALL BEARING	6202ZZ	4
9	136445	HANDLE BUSHING		2
10	SR060700	HEX SOCKET BOLT	M6x35	2

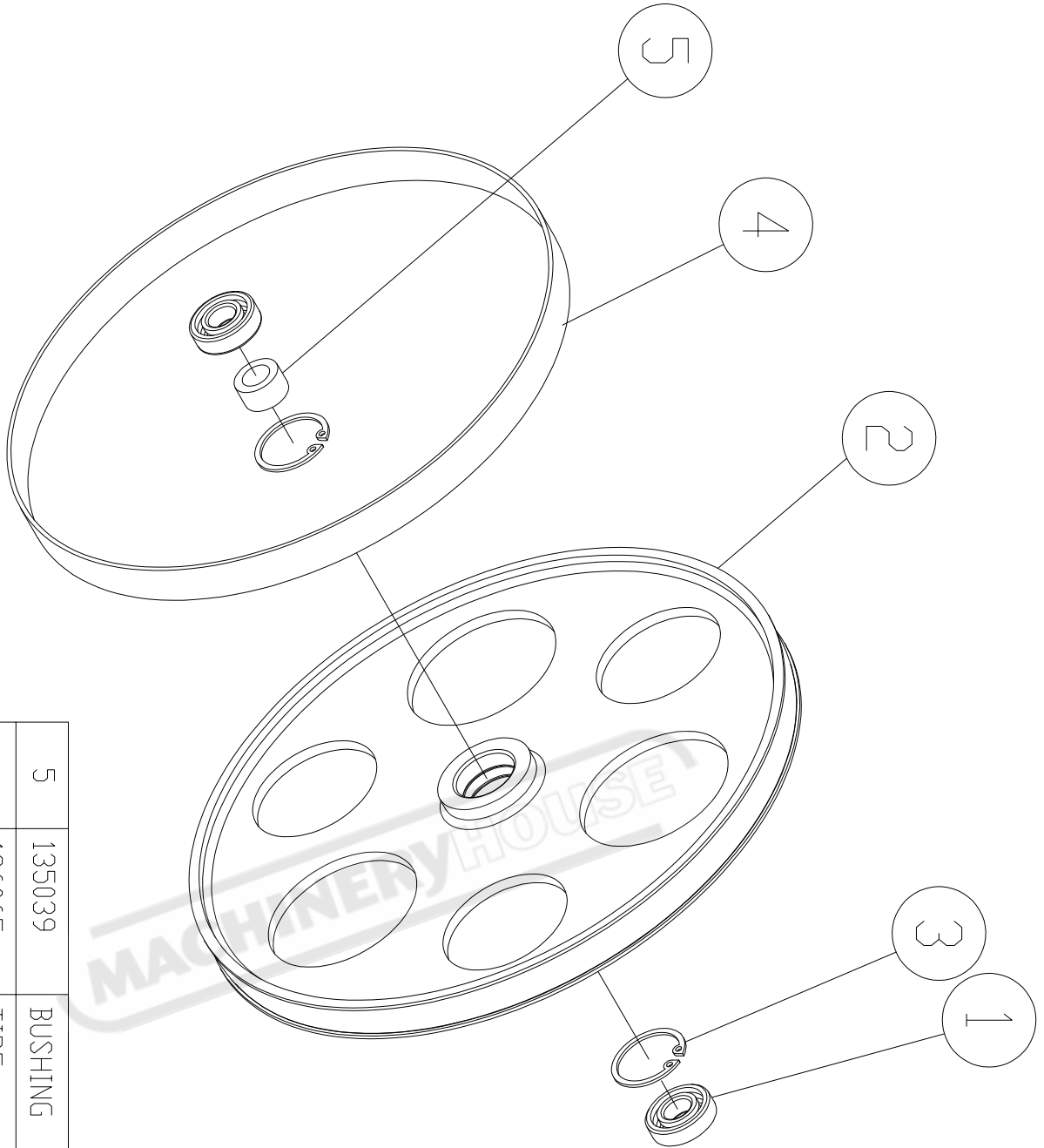

MODEL NO.:W4344
PART NO.:AB136024T-PU
UPPER WHEEL (ASM)

Item	Part NO	Description	Size	Qty
5	135039	BUSHING		1
4	136065	TIRE		1
3	RR470000	RETAINING RING	R47	2
2	136024T	UPPER WHEEL		1
1	BB620403	BALL BEARING	6204LLU	2

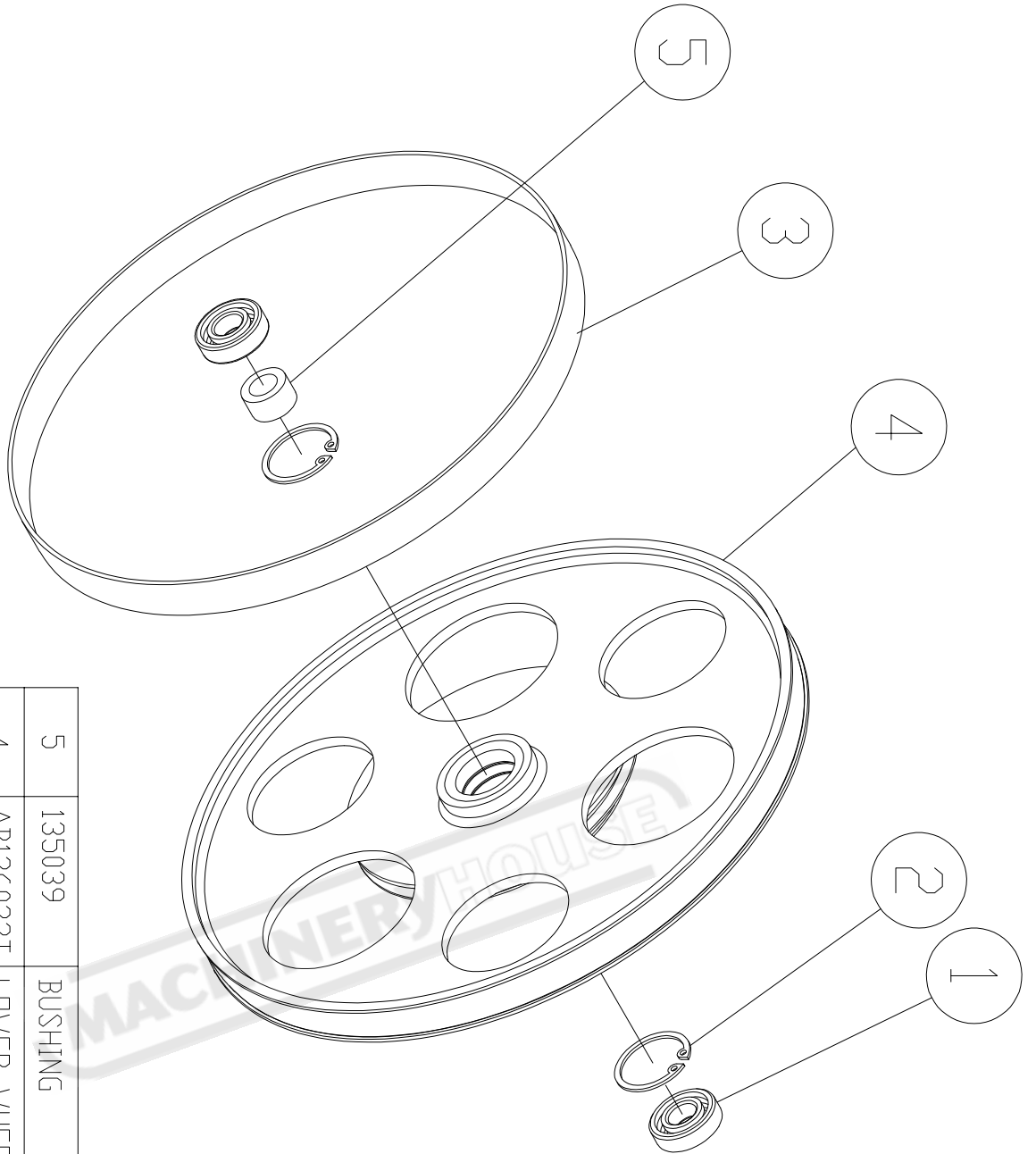

MODEL NO.:W4344
 PART NO.:AB136022T-PU
 LOWER WHEEL (ASM)

Item	Part No	Description	Size	Qty
5	135039	BUSHING		1
4	AB136023T	LOWER WHEEL ASM		1
3	136065	TIRE		1
2	RR470000	RETAINING RING	R47	2
1	BB620403	BALL BEARING	6204LLU	2

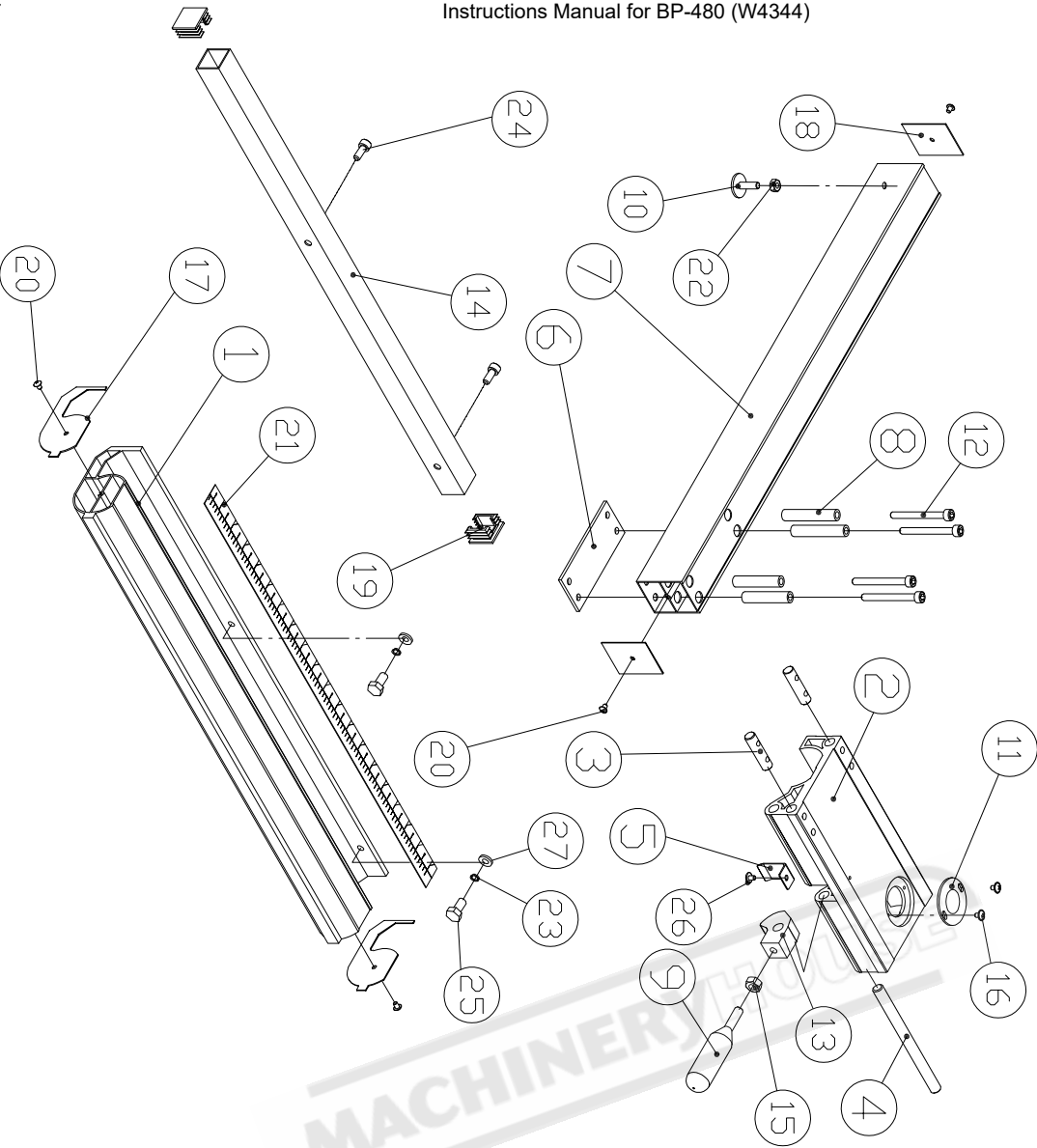

MODEL NO.: W4344
 PART NO.: AB198006
 FENCE SET

Item	Part No	Description	Size	Qty
01	198022	FIXED BASE	710	1
02	198002	ADJUST BASE		1
03	198003	FIXED SHAFT		2
04	198005	SHAFT		1
05	198006	SPRING WASHER		1
06	198008	BRACKET	T=3	1
07	198025	SUPPORT TUBE	640	1
08	198017	INTERVAL SHEATH		4
09	198013	HANDLE		1
10	198012	ADJUST SCREW		1
11	198007	CONVEX		1
12	SR062000	HEX SOCKET BOLT	M6x100	4
13	198004	FIXED LUMP		1
14	198023	SQUARE TUBE	710	1
15	NH081300	NUT	M8	1
16	SF049100	PAN HEAD BOLR W/FLANGE	M4x6	2
17	198014	GUARD PIECE		2
18	198030	GUARD PIECE		2
19	198016	PLUGGED		2
20	ST039300	TAPPING SCREW	M3.5x12	4
21	LM000539	SCALE		1
22	NH061000	NUT	M6	1
23	WS060000	SPRING WASHER	M6	2
24	SR069400	HEX SOCKET BOLT	M6x16	2
25	SH060400	HEX HEAD BOLT	M6x20	2
26	SF049200	PAN HEAD BOLR W/FLANGE	M4x8	1
27	WF061310	FLAT WASHER	M6x13	2

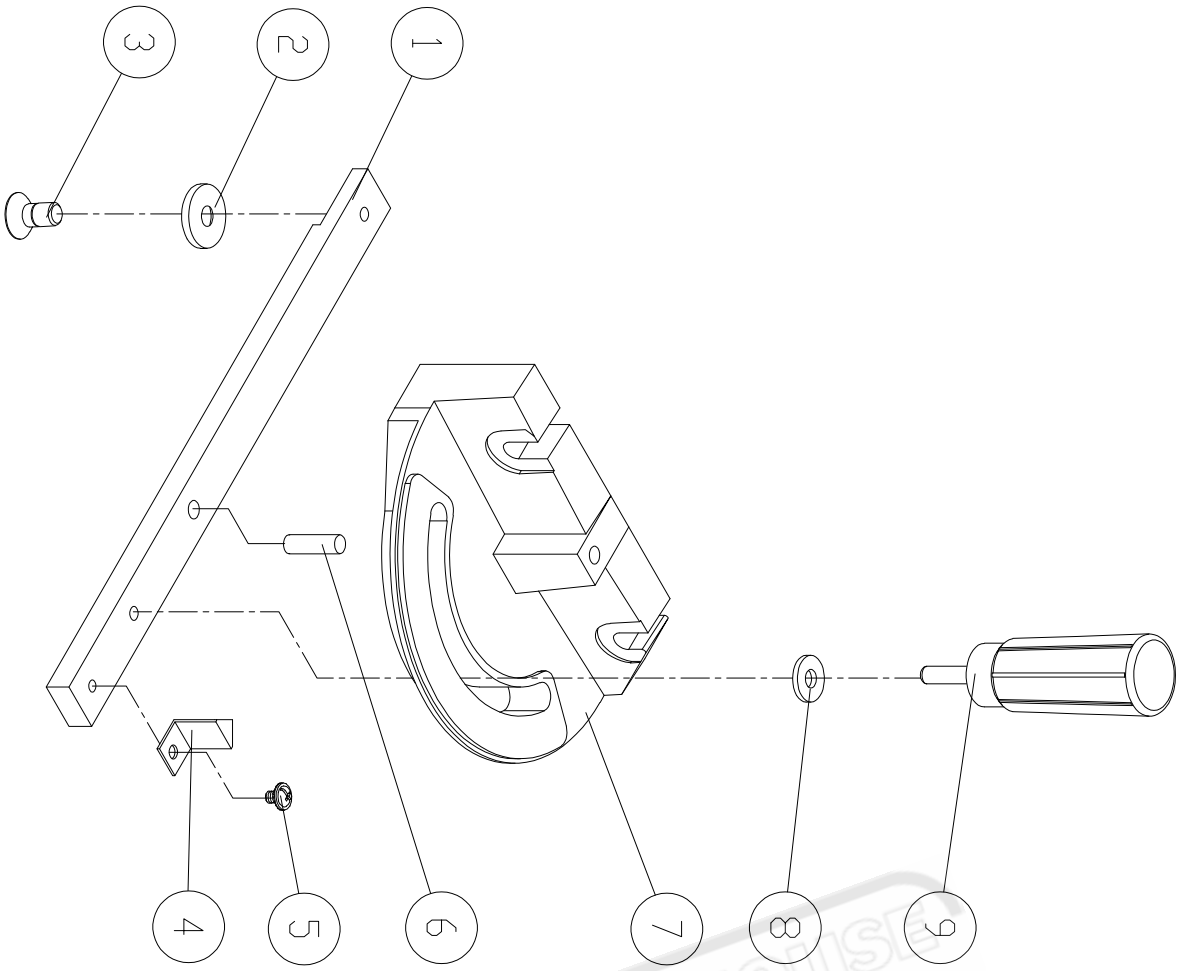

**MODEL NO.:W4344
PART NO.:AB198101
MITER GAUGE ASSY**

Item	Part NO	Description	Size	Qty
09	198105	HANDLE		1
08	198104	NYLON WASHER		1
07	198106	MITER GAUGE BODY		1
06	198107	STEEL PIN	ø6.5x10	1
05	SF059200	PAN HEAD BOLT W/FLANGE	M5x8	1
04	198103	POINTER		1
03	SN069200	COUNTER SUNK BOLT	M6x6	1
02	198102	GUIDE PIECE		1
01	198101	GUIDE BAR		1

1.5KW/240V/50Hz/1PH

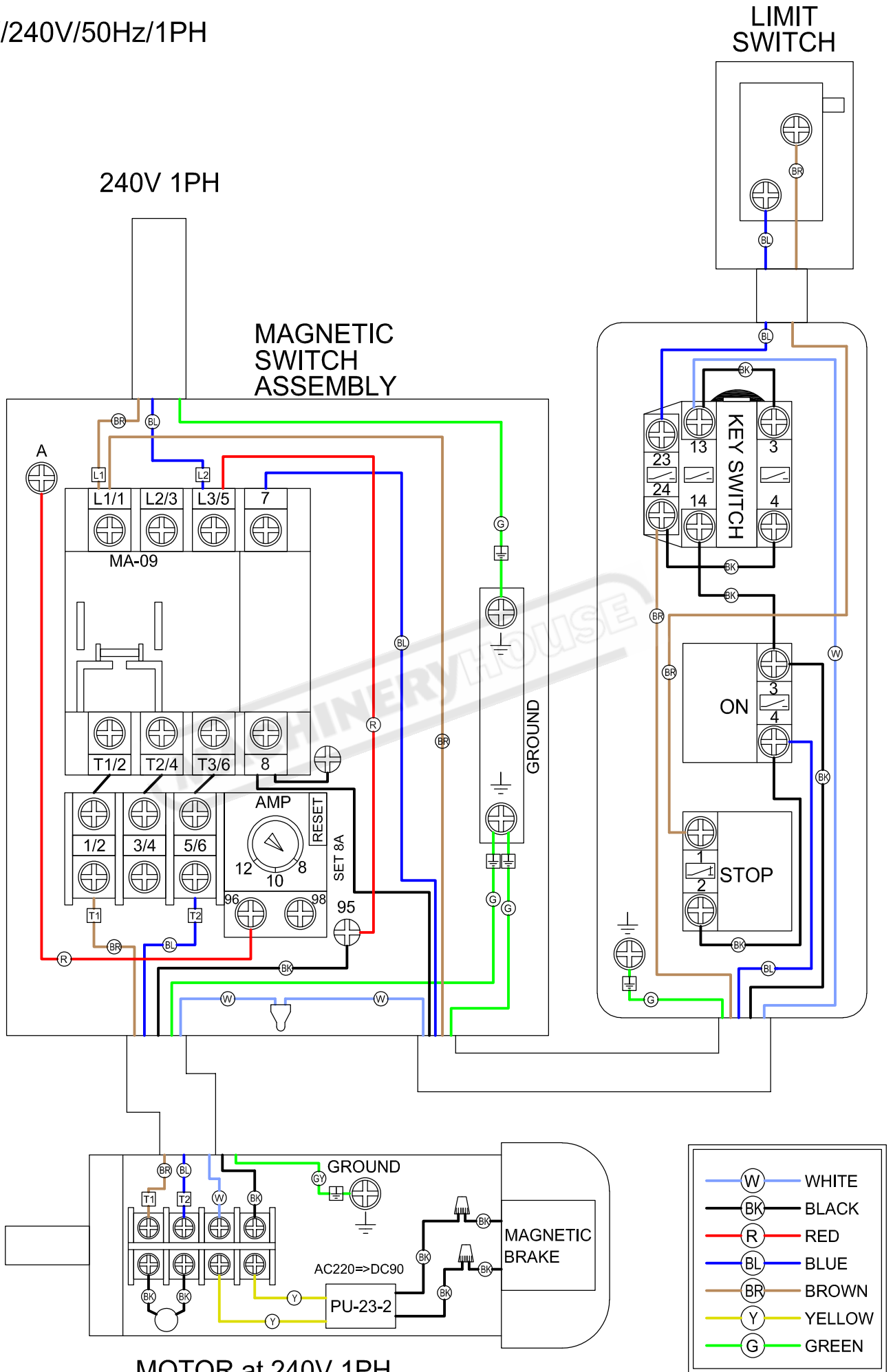



General Machinery Safety Instructions

Machinery House
requires you to read this entire Manual before using this machine.

- 1. Read the entire Manual before starting machinery.** Machinery may cause serious injury if not correctly used.
- 2. Always use correct hearing protection when operating machinery.** Machinery noise may cause permanent hearing damage.
- 3. Machinery must never be used when tired, or under the influence of drugs or alcohol.** When running machinery you must be alert at all times.
- 4. Wear correct Clothing.** At all times remove all loose clothing, necklaces, rings, jewelry, etc. Long hair must be contained in a hair net. Non-slip protective footwear must be worn.
- 5. Always wear correct respirators around fumes or dust when operating machinery.** Machinery fumes & dust can cause serious respiratory illness. Dust extractors must be used where applicable.
- 6. Always wear correct safety glasses.** When machining you must use the correct eye protection to prevent injuring your eyes.
- 7. Keep work clean and make sure you have good lighting.** Cluttered and dark shadows may cause accidents.
- 8. Personnel must be properly trained or well supervised when operating machinery.** Make sure you have clear and safe understanding of the machine you are operating.
- 9. Keep children and visitors away.** Make sure children and visitors are at a safe distance for you work area.
- 10. Keep your workshop childproof.** Use padlocks, Turn off master power switches and remove start switch keys.
- 11. Never leave machine unattended.** Turn power off and wait till machine has come to a complete stop before leaving the machine unattended.
- 12. Make a safe working environment.** Do not use machine in a damp, wet area, or where flammable or noxious fumes may exist.
- 13. Disconnect main power before service machine.** Make sure power switch is in the off position before re-connecting.
- 14. Use correct amperage extension cords.** Undersized extension cords overheat and lose power. Replace extension cords if they become damaged.
- 15. Keep machine well maintained.** Keep blades sharp and clean for best and safest performance. Follow instructions when lubricating and changing accessories.
- 16. Keep machine well guarded.** Make sure guards on machine are in place and are all working correctly.
- 17. Do not overreach.** Keep proper footing and balance at all times.
- 18. Secure workpiece.** Use clamps or a vice to hold the workpiece where practical. Keeping the workpiece secure will free up your hand to operate the machine and will protect hand from injury.
- 19. Check machine over before operating.** Check machine for damaged parts, loose bolts, Keys and wrenches left on machine and any other conditions that may effect the machines operation. Repair and replace damaged parts.
- 20. Use recommended accessories.** Refer to instruction manual or ask correct service officer when using accessories. The use of improper accessories may cause the risk of injury.
- 21. Do not force machinery.** Work at the speed and capacity at which the machine or accessory was designed.
- 22. Use correct lifting practice.** Always use the correct lifting methods when using machinery. Incorrect lifting methods can cause serious injury.
- 23. Lock mobile bases.** Make sure any mobile bases are locked before using machine.
- 24. Allergic reactions.** Certain metal shavings and cutting fluids may cause an allergic reaction in people and animals, especially when cutting as the fumes can be inhaled. Make sure you know what type of metal and cutting fluid you will be exposed to and how to avoid contamination.
- 25. Call for help.** If at any time you experience difficulties, stop the machine and call you nearest branch service department for help.



Wood Bandsaw Safety Instructions

Machinery House
requires you to read this entire Manual before using this machine.

- 1. Maintenance.** Make sure the bandsaw is turned off and disconnect from the main power supply and make sure all moving parts have come to a complete stop before any inspection, adjustment or maintenance is carried out.
- 2. Bandsaw Condition.** Bandsaw must be maintained for a proper working condition. Never operate a bandsaw that has damaged or worn parts. Scheduled routine maintenance should be performed on a scheduled basis.
- 3. Blade Condition.** Never operate a bandsaw with a dull, cracked or badly worn blade. Before using a bandsaw inspect blades for missing teeth and cracks. Replace if required.
- 4. Replacing Blade.** Make sure teeth are face forward to the workpiece and blade is properly tensioned. Wear gloves to protect hands and wear safety glasses to protect your eyes.
- 5. Use Correct Blade.** Use the correct blade for the material being cut and the type of cut you are performing.
- 6. Hand Hazard.** Keep hands and fingers clear from the line of cut of the blade. Serious injury can occur.
- 7. Leaving a bandsaw Unattended.** Always turn the bandsaw off and make sure all moving parts have come to a complete stop before leaving the bandsaw. Do not leave bandsaw running unattended for any reason.
- 8. Avoiding Entanglement.** Blade guard must be used at all times. Remove loose clothing, belts, or jewelry items. Never wear gloves while machine is in operation. Tie up long hair and use the correct hair nets to avoid any entanglement with the bandsaw moving parts.
- 9. Understand the machines controls.** Make sure you understand the use and operation of all controls.
- 10. Power outage.** In the event of a power failure during use of the bandsaw, turn off all switches to avoid possible sudden start up once power is restored.
- 11. Work area hazards.** Keep the area around the bandsaw clean from oil, tools, chips. Pay attention to other persons in the area and know what is going on around the area to ensure unintended accidents.
- 12. Workpiece Handling.** Never hold small workpieces with your fingers during a cut. Always support/feed the workpiece with push stick, table support, vice, or some sort of clamping fixture.
- 13. Hearing protection and hazards.** Always wear hearing protection as noise generated from bandsaw blade and workpiece vibration, material handling can cause permanent hearing loss over time.
- 14. Cutting techniques.** Plan your cuts so you always cut out of the wood. Do not back the workpiece away from the blade while the saw is running. If you need to back the workpiece out, turn off the bandsaw and wait till the blade has come to a complete stop, and do not twist or put excessive stress on the blade while backing work out.
- 15. Feeding material.** Always feed material evenly and smoothly. Do not force or twist blade while cutting, especially while cutting small radii material.
- 16. Job Material.** This machine is designed to cut wood only. It is not designed to cut metal or use cutting fluid. Always inspect your material before cutting. If you have any doubt about stability or structural integrity of your stock do not cut.
- 17. Starting position/speed.** Never turn the bandsaw on when the blade is resting on the workpiece. Allow blade to reach full speed before cutting.
- 18. Guards.** Do not operate bandsaw without the blade guard in place or with the doors open.
- 19. Stopping the Blade.** Do not stop or slow the blade with your hand or workpiece. Allow the blade to stop on its own, unless the machine is equipped with a brake.
- 20. Call for help.** If at any time you experience difficulties, stop the machine and call your nearest branch service department for help.

PLANT SAFETY PROGRAM

NEW MACHINERY HAZARD IDENTIFICATION, ASSESSMENT & CONTROL

Wood Bandsaw

Developed in Co-operation Between A.W.I.S.A and Australia Chamber of Manufactures
This program is based upon the Safe Work Australia, Code of Practice - Managing Risks of Plant in the Workplace (WHSA 2011 No10)

Item No.	Hazard Identification	Hazard Assessment	Risk Control Strategies <small>(Recommended for Purchase / Buyer / User)</small>
A	ENTANGLEMENT	HIGH	Eliminate, avoid loose clothing / Long hair etc.
B	CRUSHING	LOW	Ensure bandsaw is on level ground to and safe place to prevent it falling.
C	CUTTING, STABBING, PUNCTURING	MEDIUM	Blade guards should always be in the closed position before starting machine. Top blade guide system should be adjusted to suit material thickness. Isolate main power switch before changing blade, cleaning or adjusting. Use a push stick to remove off-cuts. Hands must always be kept well away from blade at all times. Check blade tracking before starting.
D	SHEARING	MEDIUM	Make sure all guards are secured shut when machine is on.
F	STRIKING	LOW	Support long heavy work pieces. Remove all loose objects around moving parts. Wear safety glasses
H	ELECTRICAL	MEDIUM	Should blade break turn off machine immediately and use foot brake to stop if supplied. All electrical enclosures should only be opened with a tool that is not to be kept with the machine.
O	OTHER HAZARDS, NOISE, DUST.	LOW	Wear hearing protection as required. Must be connected to dust extraction.
Plant Safety Program to be read in conjunction with manufactures instructions			



www.machineryhouse.com.au



www.machineryhouse.co.nz

Authorised and signed by:
Safety officer:



Manager:



Revised Date: 12th March 2012